

QG30-KI-030E-AI-K

## Inclination sensor

1 axis

Non-programmable device

Output: 4 - 20 mA

horizontal/vertical mounting

Measuring range  
± 30°



### General specifications 11315, v20210611

Housing	Plastic injection molded housing (Arnite T06 202 PBT black)
Dimensions (indicative)	30x30x15 mm
Mounting	Included: 2x M3x16 mm zinc plated steel pozidrive pan head screws, self-tapping (PZ DIN 7500CZ)
Ingress Protection (IEC 60529)	IP67
Relative humidity	0 - 95% (non condensing, housing fully potted)
Weight	approx. 15 gram (cable excluded)
Supply voltage	10 - 30 V dc
Polarity protection	Yes
Current consumption	≤ 10 mA ( excluding output signal )
Operating temperature	-25 .. +80 °C
Storage temperature	-25 .. +80 °C
Measuring range	± 30°
Centering function	No
Frequency response (-3dB)	0 - 10 Hz (±2,5 Hz)
Accuracy (overall @20°C)	0,6° typ. (offset excluded)
Offset error	± 1° typ. (± 3° 2σ)
Non linearity	± 0,4° typ.
Sensitivity error	± 2% typ., Repeatability 0.1°
Resolution	0,03°
Temperature coefficient	± 0,02°/K typ.
Max mechanical shock	3.500g
Output	4 - 20 mA
Output load	Rload ≤ (50*Vs -300) (Ω) (Eg: Vs = 24 V: Rload ≤ 900 Ω)
Short circuit protection	Yes (T<55°C), Max 10 s (T>55°C)
Output refresh rate	continuous (analog)
Programming options	not applicable

## QG30-KI-030E-AI-K

$I_{out} = 12 + 16 \cdot \sin(\alpha)$  [mA]  
 Outside measuring range sensor transfer formula is valid until clip level of approximately 2.5mA & 22.5mA

### Transfer characteristic

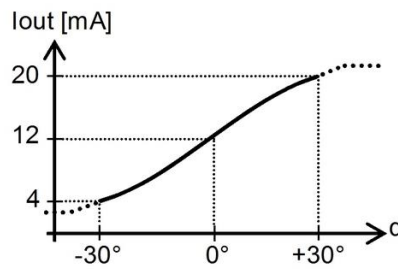

The QG30 can be used in both vertical and horizontal mounting position.

### Measurement orientation

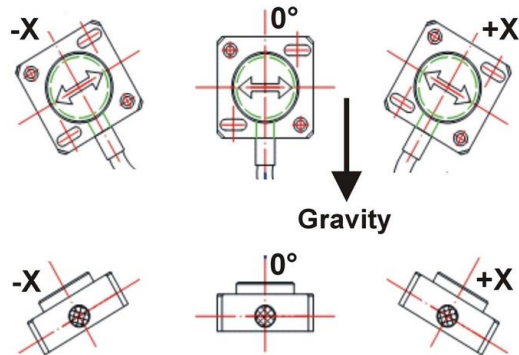

### Connectivity (cable length ±10%)

2 m PVC/PVC Liyy, black Ø 4,6 mm, wires: 3x0,34 mm<sup>2</sup> Sensor colors (static usage)

Brown	+ Supply Voltage
Black	Output
Blue	Gnd

Connection

Wire / pin coding

### Mechanical dimensions (indicative only)

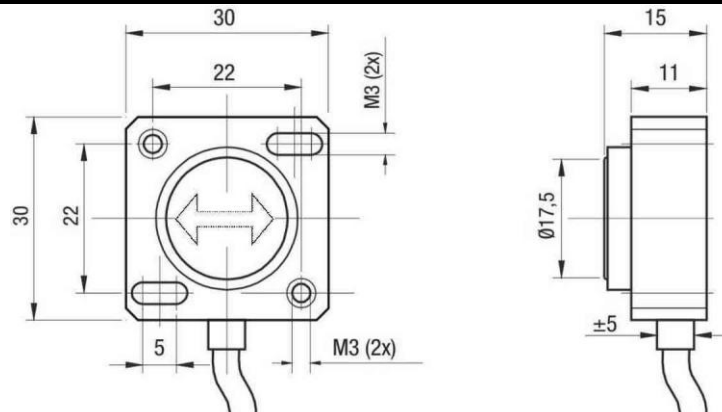

### Remarks

As this device is accelerometer-based the sensor is inherent sensitive for accelerations/vibrations. Application specific testing must be carried out to check whether this sensor will fulfil your requirements.