

QG series

QG40N-series

QG40N-KDXYh-080-ASP-CM-UL

Tilt switch

2 axis horizontal mounting

Programmable device

Output: PNP

Switch points programmable
between $\pm 1^\circ$ and $\pm 80^\circ$

Measuring range
Factory defaults: $\pm 80^\circ$



General specifications 11630, v20200925

Housing	Plastic injection molded housing (Arnite T06 202 PBT black)
Dimensions (indicative)	40x40x25 mm
Mounting	Included: 2x M3x25 mm zinc plated steel pozidrive pan head screws, self-tapping (PZ DIN 7500CZ)
Ingress Protection (IEC 60529)	IP67, IP69K
Relative humidity	0 - 95% (non condensing, housing fully potted)
Weight	approx. 45 gram
Supply voltage	6 - 30V dc
Polarity protection	Yes
Current consumption	≤ 25 mA
Operating temperature	-40 .. +60 °C
Storage temperature	-40 .. +85 °C
Measuring range	Factory defaults: $\pm 80^\circ$
Centering function	Yes (0°), range: $\pm 5^\circ$
Frequency response (-3dB)	0-0,7 Hz
Typ. Accuracy @20°C (2σ)	$\pm 0,5^\circ$
Offset error	0° (after zeroing)
Non linearity	not applicable
Sensitivity error	not applicable
Resolution	$0,1^\circ$
Temperature coefficient	$\pm 0,04^\circ/\text{K}$ typ.
Max mechanical shock	10.000 g
Output	dual PNP
Output load	150 mA cont., 250 mA max 10 sec., protected against back EMF
Short circuit protection	Yes (max 10 s)
Boot time	< 100 ms
Programming options	by optional QG40N-configurator (switch points, delay times, filtering)

QG40N-KDXYh-080-ASP-CM-UL

2 independent PNP outputs:
 - Programmable switchpoints $\pm S$ (optional QG40N Configurator)
 - Operation zone: conducting
 - Critical zone: non-conducting
 - Unpowered sensor: non-conducting

Factory defaults:
 - Switchpoint $\pm S$ output X: $\pm 80^\circ$
 - Switchpoint $\pm S$ output Y: $\pm 80^\circ$
 - hysteresis: $0,5^\circ$
 - operation \blacktriangleright critical delay : 0,5 s
 - critical \blacktriangleright operation delay : 1 s

Transfer characteristic

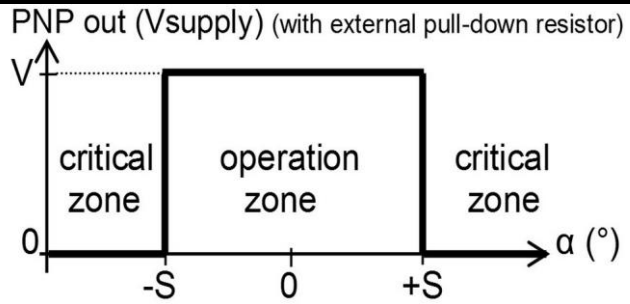

The default 0° position is when the sensor is mounted horizontally (round nose upwards) and no acceleration is applied.

Only one axis may exceed 45° tilt.

Zeroing: eliminate mech. offsets
 Connect zeroing input to ground (>0,5sec) within 1 min. after power up. Normally the zeroing input should be left unconnected.

Zeroing is possible within $\pm 5^\circ$ tilt.

Measurement orientation

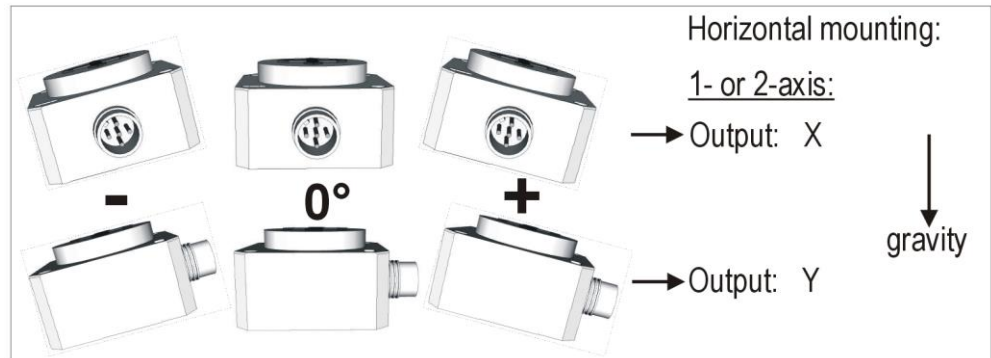

Connection

Wire / pin coding

Connectivity (cable length $\pm 10\%$)

M12 5p male connector (Glass fibre reinforced grade, contacts CuZn pre-nickel galvan. Au)

Pin 1: + Supply Voltage
 Pin 2: output Y
 Pin 3: Gnd
 Pin 4: output X
 Pin 5: zeroing

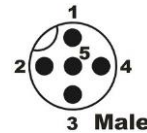

If connected with M12 F (accessory sold by DIS):

Brown: + Supply Voltage
 White: output Y
 Blue: Gnd
 Black: output X
 Green/yellow: zeroing

Mechanical dimensions (indicative only)

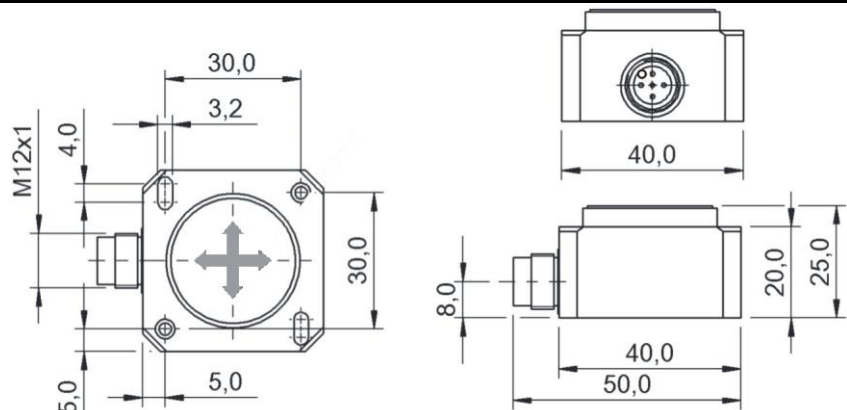

QG series



Intended use, UL, Remarks

QG series sensors are intended to measure inclination, acceleration or tilt angle after installing in machines, equipment and systems. Flawless function in accordance with the specifications is ensured only when the device is used within its specifications.

This device is not a safety component according to the EU Machine Directive (ISO13849). For full redundancy two devices can be used in the application.

Modifications or non-approved use are not permitted and will result in loss of warranty and void any claims against the manufacturer.

UL & c-UL listed product (File number E312057, UL508 standards UL60947-5-2 & CSA-C22,2 No. 14)

Product Identity / Category Code Number (CCN): Industrial Control Equipment / NRKH & NRKH7

Enclosure rating: type 1, Ambient temperature: max 80 °C (see also datasheet, lowest value applies)

Electrical ratings: Intended to be used with a Class 2 power source in accordance with UL1310,

max. input Voltage 32V dc (see also datasheet, lowest value applies), max. current 200mA

Accessory Cable Assembly: Any UL-listed (CYJV/7) mating connector with mechanical locking, wire thickness of at least 30 AWG (0,05 mm²), recommended \leq 23 AWG (\geq 0,25 mm²)

As this device is accelerometer-based the sensor is inherent sensitive for accelerations/vibrations.

Application specific testing must be carried out to check whether this sensor will fulfil your requirements.