

QG series

QG40N-series SIL CL 1 / PLc

QG40N-KAXYh-7,0-ASP-CM-UL-1c

Acceleration switch for SIL CL 1 (acc. to IEC 62061) PLc (acc. to EN ISO 13849) applications

2 axis horizontal mounting

Factory programmable only
Output: PNP

Mode:
PEAK, 40ms measuring interval
(optional: RMS-mode,
factory progr. measuring interval)

Measuring range
0.1 to 7g (factory programmable)



General specifications 12714, v20210611

Housing	Plastic injection molded housing (Arnite T06 202 PBT black)
Dimensions (indicative)	40x40x25 mm (download 3D stepfile from dis-sensors.com)
Mounting	Included: 2x M3x25 mm zinc plated steel pozidrive pan head screws, self-tapping (PZ DIN 7500CZ) Mounting on flat surface only. Screw with maximum Torque 2 Nm
Ingress Protection (IEC 60529)	IP67, IP69K (with IP69K mating connector)
Relative humidity	0 - 95% (non condensing, housing fully potted)
Weight	approx. 45 gram
Supply voltage	5- 32 V dc
Polarity protection	Yes
Current consumption	≤ 20 mA
Operating temperature	-40 .. +60 °C
Storage temperature	-40 .. +85 °C
Measuring range	0.1 to 7g (factory programmable)
Centering function	Yes (0°), range: ±5°
Frequency response (-3dB)	0- 1600 Hz
Accuracy (overall @20°C)	0,05g typ.
Offset error	not applicable after zeroing
Non linearity	not applicable
Sensitivity error	not applicable
Resolution	0,01 g
Temperature coefficient	± 0,3 mg/K typ.
Max mechanical shock	10.000g
Output	dual PNP
Output load	2x 200 mA continuously, outputs protected against back EMF
Short circuit protection	Yes
Boot up time / response time	< 1s (non conducting during boot-up) / 40ms
Programming options	Factory only (Peak/RMS mode, switch points, delay time, RMS mode measuring interval)

QG series

QG40N-KAXYh-7,0-ASP-CM-UL-1c

PNP-output:
 - Switchpoints $\pm S$
 - Operation zone, conducting
 - Critical zone: non-conducting
 - Diagnostic error: non-conducting
 - Unpowered sensor: non-conducting

Factory defaults:
 - Mode: peak detection
 - Measuring interval: 40ms fixed
 - Output X: S = 7g
 - Output Y: S = 7g
 - critical_to_operation delay : 1 s

Measuring data explained:

PEAK mode:
 - Sensor samples with 3200Hz
 - Fixed 40ms measuring interval
 - Both positive and negative accelerations are taken into account
 - Each 40ms the measured peak value is checked against the switched point.

Optional RMS mode:
 - Sensor samples with 3200Hz
 - Factory programmable measuring interval ($n \cdot 40ms$), max 10sec
 - After each measuring interval the RMS value is checked against the switched point.

The default 0 g position is when the sensor is mounted horizontally (round nose upwards or downwards) and no acceleration is applied.

Connection

Wire / pin coding

Transfer characteristic

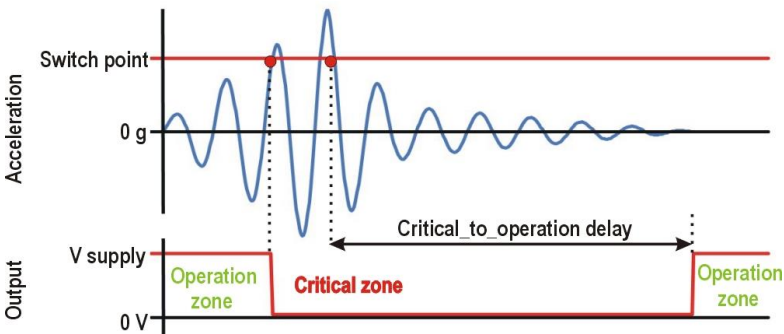
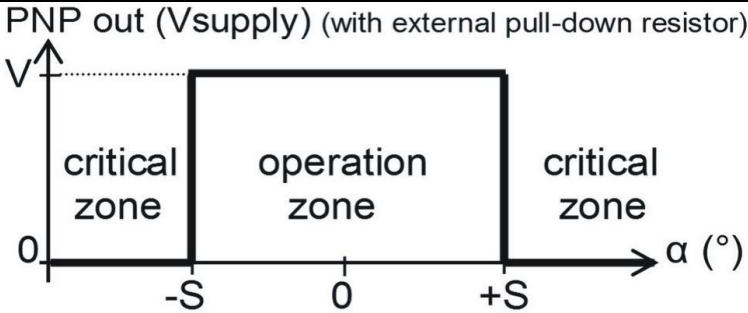

Measurement orientation

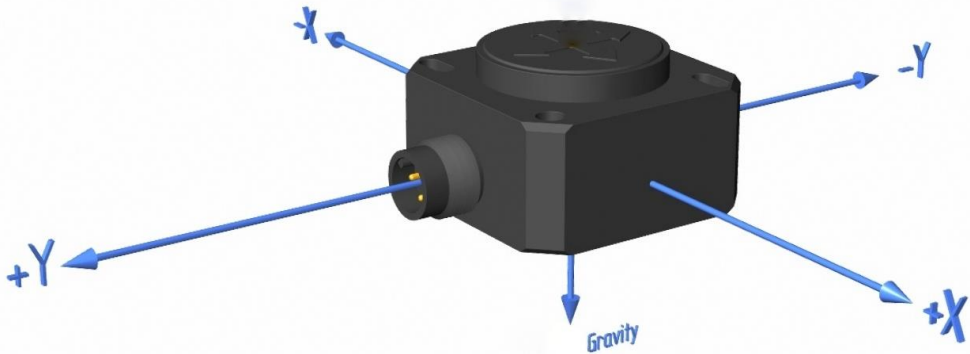

Connectivity (cable length $\pm 10\%$)

M12 5p male connector (Glass fibre reinforced grade, contacts CuZn pre-nickelated galv. Au)

- Pin 1: + Supply Voltage
- Pin 2: output Y
- Pin 3: Gnd
- Pin 4: output X
- Pin 5: zeroing

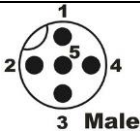

If connected with M12 F (accessory sold by DIS):

- Brown: + Supply Voltage
- White: output Y
- Blue: Gnd
- Black: output X
- Green/yellow: zeroing

Mechanical dimensions (indicative only)

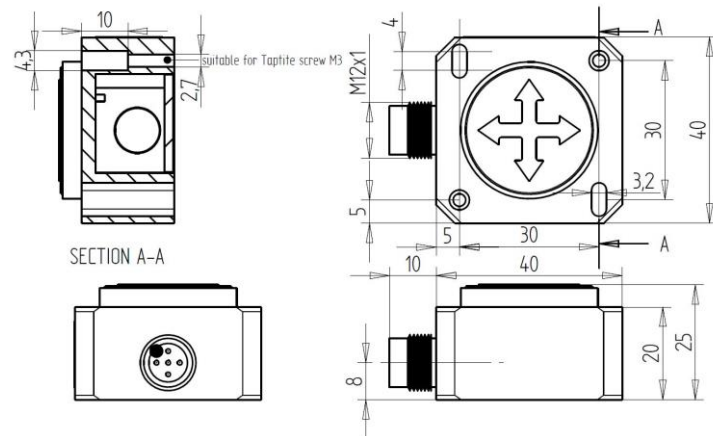

Safety Information, Intended use, UL, Remarks, Ordering

QG series sensors are intended to measure inclination, acceleration or tilt angle after installing in machines, equipment and systems. Flawless function in accordance with the specifications is ensured only when the device is used within its specifications.

Modifications or non-approved use are not permitted and will result in loss of warranty and void any claims against the manufacturer.

Safety information:

- Read this datasheet carefully before using this device in a safety application
- Read the safety manual first (download from dis-sensors.com)
- Read the Declaration of Conformity (download from dis-sensors.com)
- Safety level: SIL CL 1 (acc. to IEC 62061), PLc (acc. to EN ISO 13849)
- Judgement if this device can be used as safety device in customers application is the solely responsibility of the customer involved. Calculations can be based on these figures:
 - Hardware architecture: HFT=0 (according IEC 62061), CAT.2 (according to EN ISO 13849)
 - MTTFd: 415 years, DC: >60% ("low"), CCF: 65pt, SFF: >60%, PFHD:1,5E-07
 - Error: any diagnostic error will force both sensor outputs to "non-conducting" (low)
 - MCU Unknown interrupt
 - MCU RAM error
 - MCU FLASH error
 - MCU EEPROM error
 - MCU Watch Dog error
 - Sensor Self-test error
 - Sensor Interrupt error
 - Sensor Data format sensor error
 - Measurement error (fault in sensor element)
 - output error (output is not equal to processor output)
 - voltage error
- If the sensor output becomes non-conducting (low) during operation the controller of the application involved should take appropriate action to prevent hazardous situations. This situation can be caused by a real hazardous situation, by a defect in the sensor itself or by an external cause (e.g. in the wiring). Only if the sensor output remains non-conducting (low) after a power cycle and booting up in 'operation zone', the sensor is defective
- If the device does not meet the safety requirements for an application it can be used redundant.
- Safety Related Fault Respones Time (SRFRT): <300ms
- Proof test interval (mission time): 20 years

UL & c-UL listed product (File number E312057, UL508 standards UL60947-5-2 & CSA-C22,2 No. 14)

Product Identity / Category Code Number (CCN): Industrial Control Equipment / NRKH & NRKH7

Enclosure rating: type 1, Ambient temperature: max 80 °C (see also datasheet, lowest value applies)

Electrical ratings: Intended to be used with a Class 2 power source in accordance with UL1310,

max. input Voltage 32V dc (see also datasheet, lowest value applies), max. current 200mA

Accessory Cable Assembly: Any UL-listed (CYJV/7) mating connector with mechanical locking, wire thickness of at least 30 AWG (0,05 mm²), recommended ≤23 AWG (≥0,25 mm²)

As this device is accelerometer-based the sensor is inherent sensitive for accelerations/vibrations. Application specific testing must be carried out to check whether this sensor will fulfil your requirements.

Ordering:

If a different setting for one or more parameters is required we offer a factory program service.

Please specify:

- PEAK or RMS mode (PEAK mode has fixed 40ms measuring interval)
- If RMS mode, specify the required Measuring Interval (n * 40ms) where n = integer)
- switch value Output 1
- switch value Output 2
- Critical to operation delay